

# McALPINE

## Perfect Grind®

### Waste Disposal Units



#### Contact

McAlpine & Co Ltd.  
Kelvin Avenue, Hillington  
Glasgow, G52 4LF

#### Phone & Fax

Tel: 0141 882 3213  
Fax: 0141 891 5065  
Fax: (Sales Office) 0141 883 5697

#### Online

[marketing@mc Alpineplumbing.com](mailto:marketing@mc Alpineplumbing.com)  
[www.mcalpineplumbing.com](http://www.mcalpineplumbing.com)

# Perfect Grind<sup>®</sup> Waste Disposal Units



An **environmentally sound solution** to the growing problem of food waste.

- **25% more torque** than other brands provides more grinding power
- Unique permanent magnet motor produces **higher RPM** (revolutions per minute) than AC (alternating current) induction motors
- Corrosion proof cast **stainless steel** impellers on all models
- 180° dual swivel anti-jam impellers **prevent jamming**
- **High efficiency** performance saves time, water and energy
- Motor incorporates **sound eliminating** insulation technology for quiet operation
- **BioGuard antimicrobial** eliminates bacteria and odours
- Power cord included
- Supplied with **90° Bend x 1½"** BSP thread for connection to trap

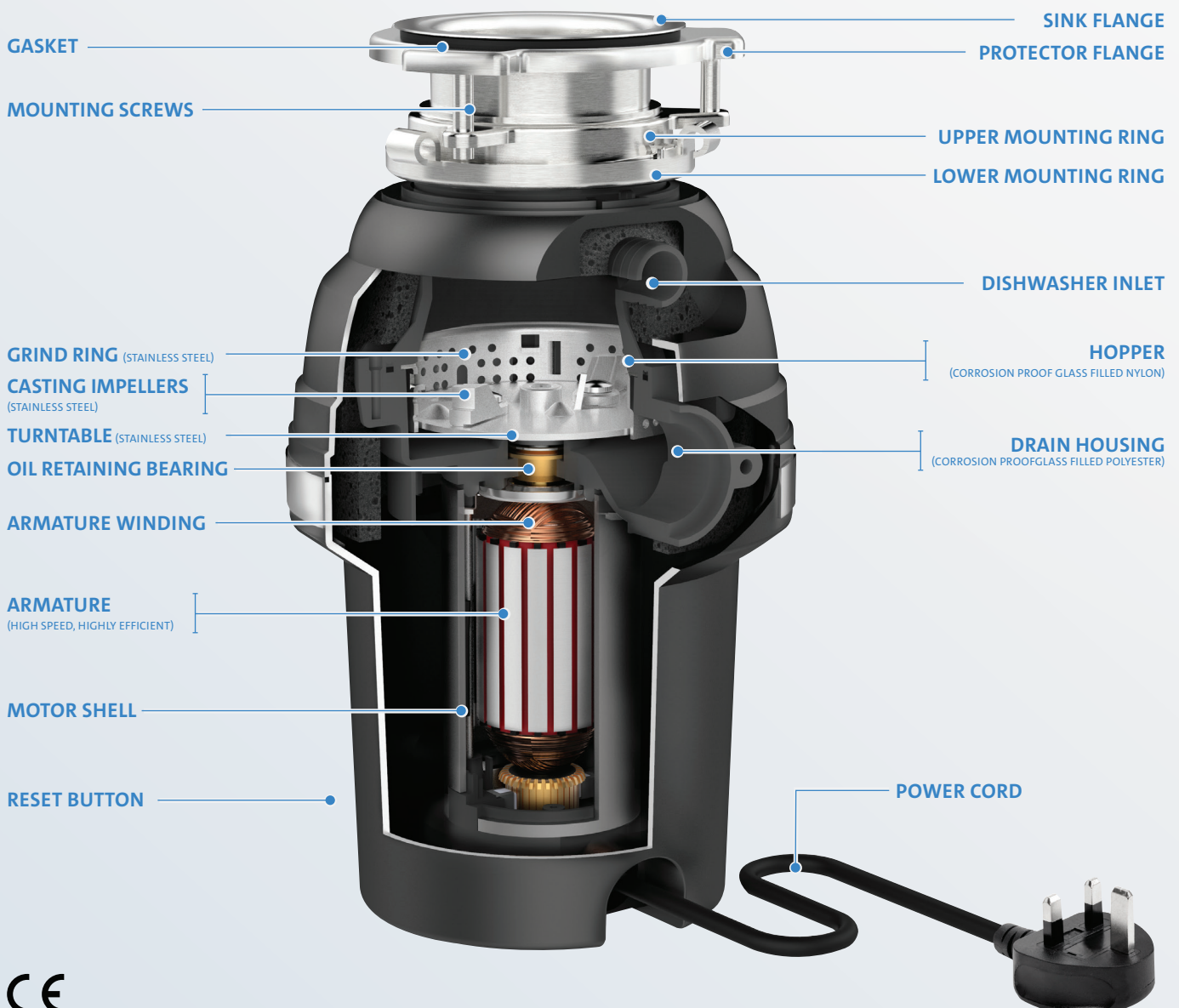
## Product Features



# Waste Disposal Units

Product	Code	Level	HP-RPM	Warranty	Fixing System	Grinding System	Switch	Noise Level
	WDU-1ASUK	Entry	½ HP - 2500 RPM	3 Year	3 Bolt	Stainless Steel	Built-in Air Switch	51-53dBA
	WDU-2ASUK	Mid	¾ HP - 2500 RPM	5 Year	3 Bolt	Stainless Steel	Built-in Air Switch	51-53dBA
	WDU-3ASUK	High	¾ HP - 2500 RPM	8 Year	3 Bolt	Stainless Steel	Built-in Air Switch	56.4 dBA
	WDU-4ASUK	High	1¼ HP - 2500 RPM	10 Year	3 Bolt	Stainless Steel	Built-in Air Switch	56-57dBA

## Perfect Grinding System

Perfect Grind® System can efficiently grind the toughest bones **faster and finer** than other brands and is safe for any properly sized septic system. **Wear resistant and corrosion proof.**

- Stainless steel, high precision, high speed dynamic balanced grinding turntable
- Stainless steel dual swivel anti-jam impellers prevent jamming
- Stainless steel grinding rings
- Specially designed large opening, round holes and arch cutters

## Batch Feed Kit

For converting continuous feed models to feed allowing the disposal unit cover to be used as an on/off switch.



## Corrosion Proof Grinding Chamber

Grinding chamber is constructed with the proven durability of glass filled nylon for **lasting performance** and is treated with **BioGuard antimicrobial** odour protection.



## Air Switch Adaptor

All WDU's include a Chrome air switch adaptor. Chrome and Matt Black air switches are available separately.



# Technical Specifications

**WDU-1ASUK** - Perfect Grind® continuous feed ½ HP Food Waste Disposer Hopper Capacity 857ml

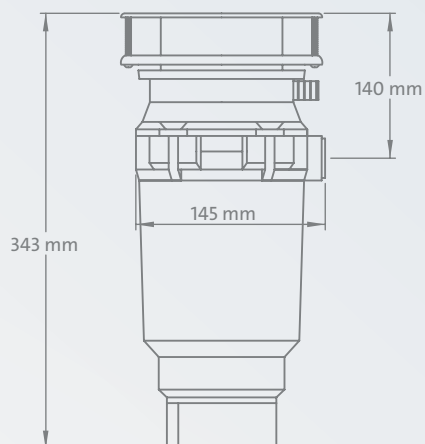

**WDU-2ASUK** - Perfect Grind® continuous feed ¾ HP Food Waste Disposer Hopper Capacity 1070ml

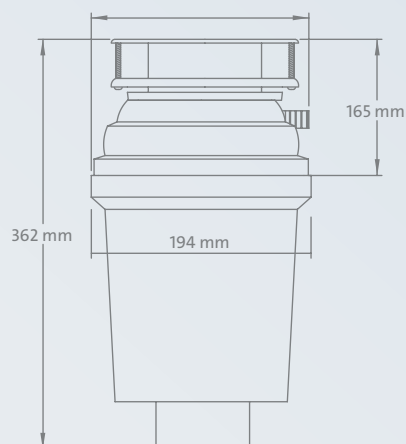

**WDU-3ASUK** - Perfect Grind® continuous feed ¾ HP Food Waste Disposer Hopper Capacity 1070ml

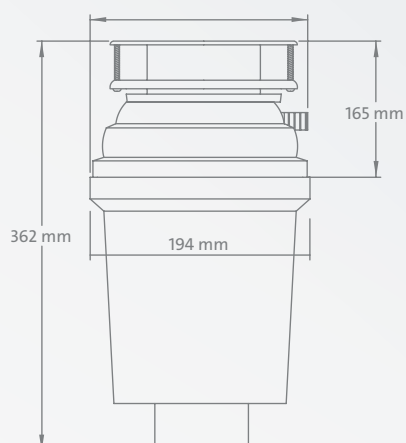

**WDU-4ASUK** - Perfect Grind® continuous feed 1¼ HP Food Waste Disposer Hopper Capacity 1070ml

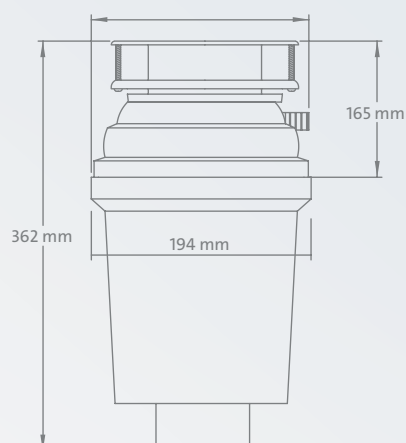

## Waste Disposer Technical Specs

<b>Motor Type</b>	Permanent Magnet	<b>Sink Flange</b>	Stainless Steel
<b>Feed</b>	Continuous	<b>Basket Strainer</b>	Stainless Steel
<b>Volts</b>	220-240V	<b>Drain Elbow</b>	ABS
<b>Frequency</b>	50/60Hz	<b>Bearings</b>	Permanently Lubricated, Sleeve Type
<b>Motor Speed</b>	2500RPM	<b>Manual Reset</b>	Protection for Overload and Temperature.
<b>Balance Level</b>	G.04		
<b>Turntable</b>	Stainless Steel		
<b>Grind Rings</b>	Stainless Steel		

## Contact

McAlpine & Co Ltd.  
Kelvin Avenue, Hillington  
Glasgow, G52 4LF

## Phone & Fax

Tel: 0141 882 3213  
Fax: 0141 891 5065  
Fax: (Sales Office) 0141 883 5697

## Online

marketing@mc Alpineplumbing.com  
www.mcalpineplumbing.com